



NAN HUA PRIMARY SCHOOL
SEMESTRAL ASSESSMENT 2 – 2012
PRIMARY 5

SCIENCE

BOOKLET A

30 Multiple Choice Questions (60 marks)

Total Time for Booklets A and B : 1 hour 45 minutes

INSTRUCTIONS TO CANDIDATES

1. Write your name and index number in the space provided.
2. Do not turn over the page until you are told to do so.
3. Follow all instructions carefully.
4. Answer all questions.
5. Shade your answers in the Optical Answer Sheet (OAS) provided.

Marks Obtained

Booklet A		/ 60
Booklet B		40
Total		/100

Name: _____ () Class: P 5 _____

Date : 23 October 2012 Parent's Signature: _____

Section A: (30 x 2marks = 60marks)

For each question from 1 to 30, four options are given. One of them is the correct answer. Make your choice (1, 2, 3 or 4). Shade the correct oval (1, 2, 3 or 4) on the Optical Answer Sheet.

1. Which of the following statement(s) about the importance of water to plants is/are true?

- A Water helps keep the plant firm.
- B Plants need water to make food during photosynthesis.
- C Water helps dissolve mineral salts in the soil which are then absorbed by the plant.

- (1) A only
- (2) B only
- (3) B and C only
- (4) A, B and C

2. In the forest, the rain tree obtains energy from the _____ while the monkey gets its energy from _____.

(1)	sun	banana plant
(2)	rain	sun
(3)	fungi	rain
(4)	leaf litter	ferns

3. Farmers would remove the adult banana plant after harvesting the first bunch of fruit. How is this beneficial to the new banana plants?

- (1) Animals would not be attracted to eat its fruits.
- (2) The fruits of the banana plant could be dispersed quickly.
- (3) The adult banana plant would be able to reproduce more quickly.
- (4) The adult banana plant would not compete with its young for water, space and sunlight.

4. Which of the following statements about the respiratory system are correct?

- A The nose hairs trap dust.
- B The lungs are made up of air sacs.
- C The windpipe leads to the stomach as well.
- D The nose, windpipe and lungs are lined with hairs.

- (1) A and B only
- (2) A and C only
- (3) A, B and D only
- (4) B, C and D only

5. Which one of the following statements is not true?
- (1) A cell is the smallest building block of life.
 - (2) Different cells are different in size and function.
 - (3) Cell division allows damaged or old cells to be replaced.
 - (4) Plant and animal cells are similar because both have a cell wall.

6. Gopal sets up a circuit as shown in the diagram. Four new batteries are put in a battery holder. The bulb does not light up.

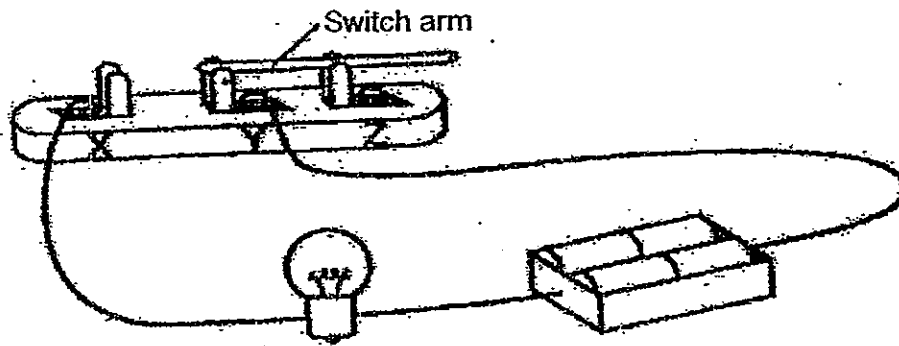

What should he do to make the bulb light up?

- A Rearrange the batteries.
 - B Connect the wire to Z instead of Y.
 - C Connect the switch arm to X instead of Z.
 - D Connect one end of the wire to tip of the bulb.
- (1) A and C only
 - (2) C and D only
 - (3) B, C and D only
 - (4) A, B and D only

7. A potted plant was left in a dark room for 1 day. Then it was put under sunlight and watered every day. Three leaves were wrapped with different materials. A few very tiny holes were pierced in all the materials for air to enter.

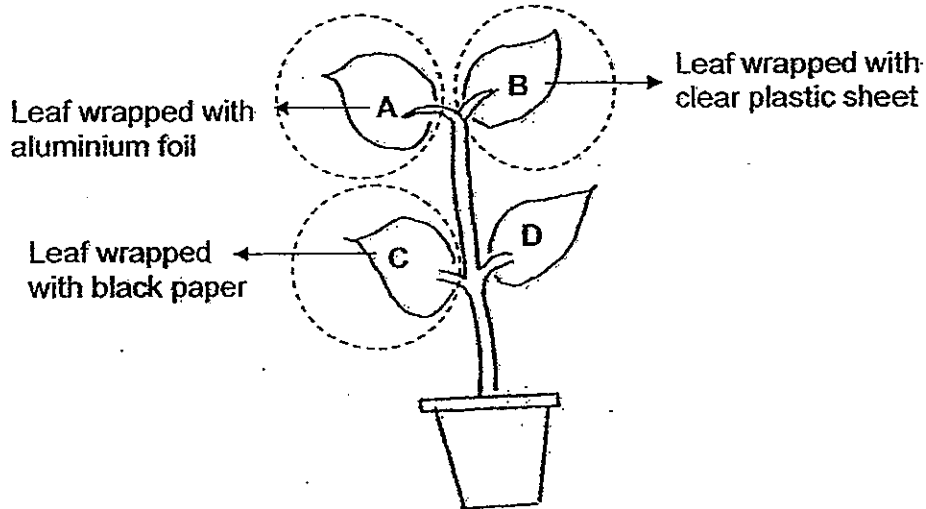

When tested with iodine solution, on which leaf/leaves would the iodine solution remain yellowish brown?

- (1) D only
 - (2) A and C only
 - (3) B and D only
 - (4) A, B and C only
8. Look at the part marked 'X' of the ginger plant.

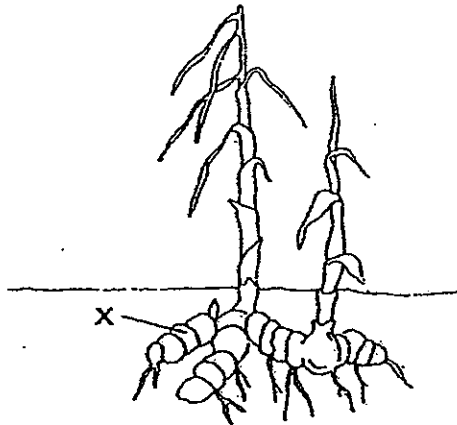

Which one of the following identifies the part 'X' and its function?

	Part	Function
(1)	Underground stem	For making food
(2)	Underground root	For absorbing water
(3)	Underground stem	For storing food
(4)	Underground root	For reproduction

9. The diagram below shows the human digestive system.

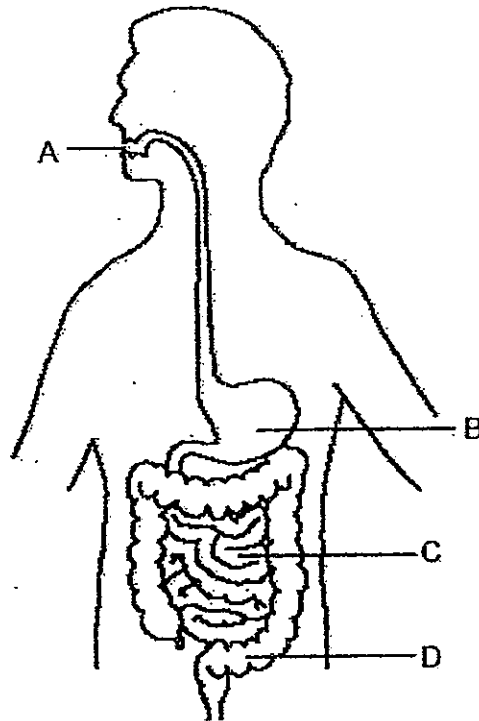

Which of the following correctly describes the processes of digestion at A, B, C and D?

	A	B	C	D
1.	Saliva mixes with the food in the mouth	Digestive juices soften the food	Food is moved into D to be absorbed into the bloodstream	Digested food is absorbed into the bloodstream
2.	Digestion begins with the help of saliva	Food is broken down into simpler substances	Digestion ends with food being absorbed into the bloodstream	Water and some mineral salts are absorbed
3.	Saliva is produced to soften the food	Digested food is absorbed into the bloodstream	Food is further broken down into simple substances	Waste materials are passed out of the body
4.	Chewed food is swallowed	Food is mixed with the blood	Food is moved into D to be absorbed into the blood stream.	Digested food is absorbed into the body

15. The diagram below shows 3 important systems in the human body.

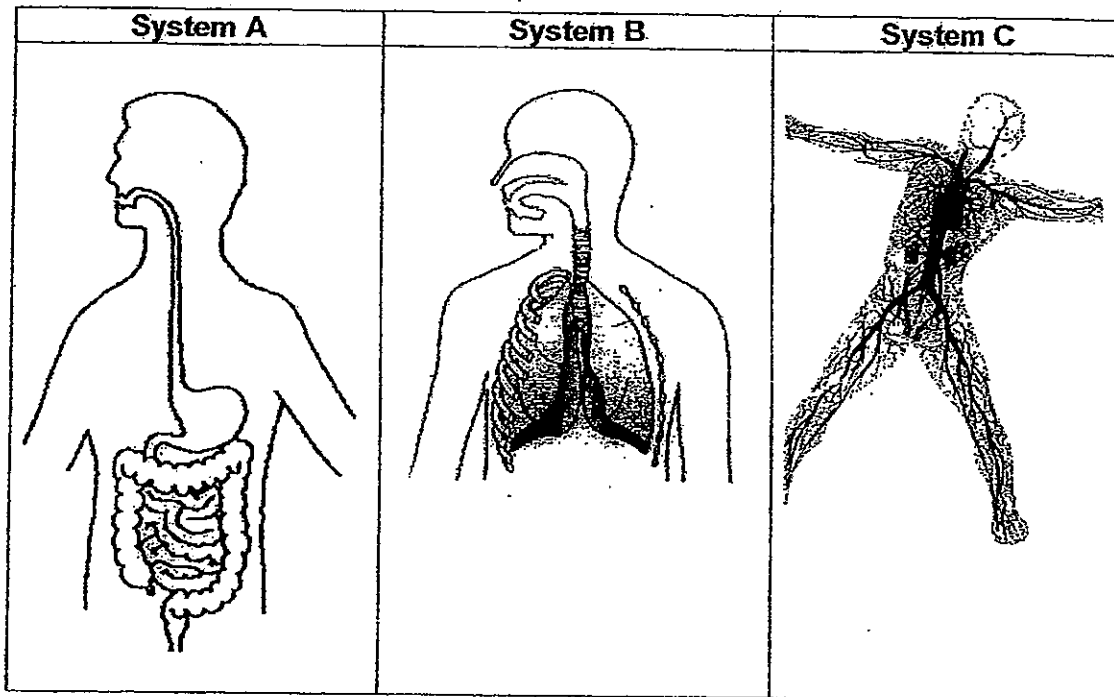

Which of the following statements about these systems are true?

- A System C gives support and shape to the body.
- B System B oxygenates the fluid that is brought to it by System C.
- C System A provides the glucose needed by the body for respiration.
- D Fluid in System C helps to transport oxygen, water and minerals to various parts of the body.

- (1) A and C only
- (2) B and D only
- (3) A, B and C only
- (4) B, C and D only

16. Mei Ling cut a cross-section of a stem of a plant and dipped it in iodine solution. Which one of the following shows what she is likely to observe?

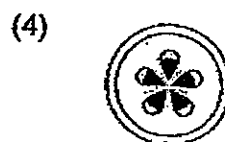
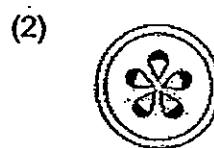

17. A farmer wanted to find out if the types of fertilizer used will affect the number of plants grown. He used 3 similar plots of land, P, Q and R, and applied the same amount of fertilizers to two of the plots. He used fertilizer A in plot Q and fertilizer B in plot R. He recorded the number of plants at the end of his test.

Which of the following graphs shows the results at the end of his test?

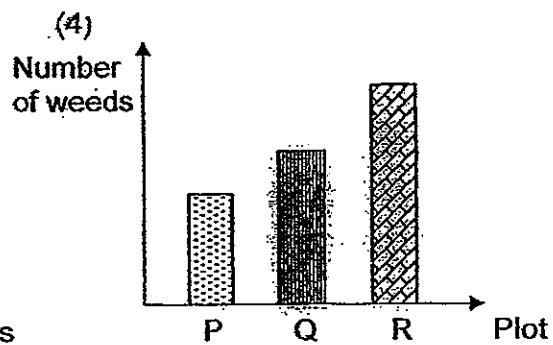
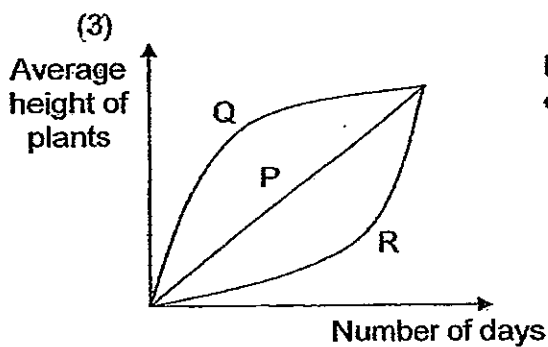
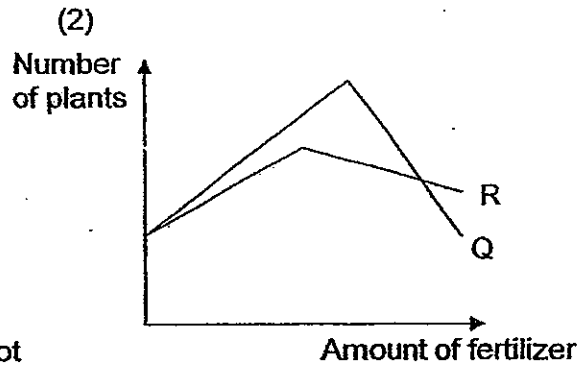
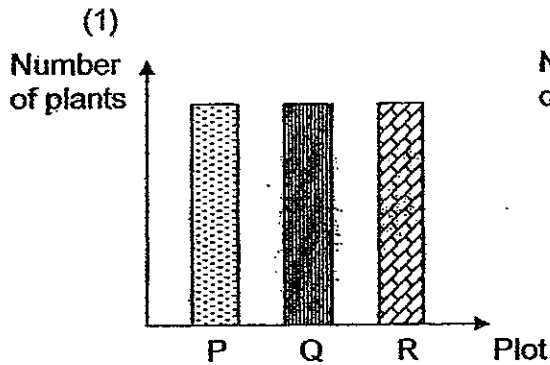

18. The table below provides some information on three cells X, Y and Z. A tick (✓) indicates the presence of the part of a cell.

		Cell X	Cell Y	Cell Z
Part	Nucleus	✓	✓	✓
	Chloroplast		✓	
	Cell wall	✓	✓	

Where are cells X, Y and Z likely to be found?

	Cell X	Cell Y	Cell Z
(1)	Cheek	Leaf	Root
(2)	Leaf	Root	Cheek
(3)	Root	Cheek	Leaf
(4)	Root	Leaf	Cheek

19. P and Q are natural substances found in two animal cells X and Y. The two cells, X and Y, are placed in some water. After a few minutes, James removed the cells from the water and examined them under a microscope.

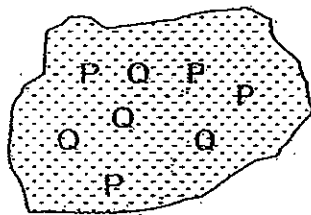

Before – Cell X

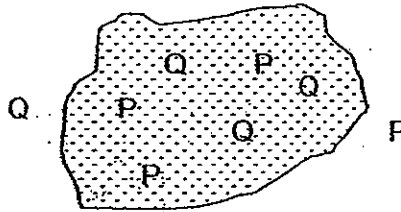

After – Cell X

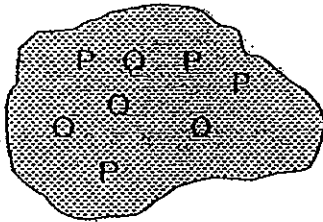

Before – Cell Y

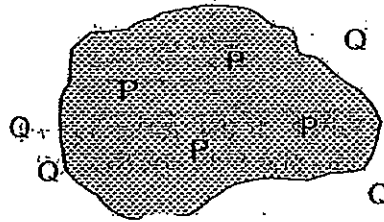

After – Cell Y

Based on his observations, James came to the following conclusions.

- A The cell membrane of Cell X is thicker than that of Cell Y.
- B Substance Q cannot pass through the cell membrane of Cell Y.
- C The cell membrane of Cell X allows both substances P and Q to pass through.
- D Substance Q is able to pass through the cell membrane of Cell X at a faster rate than that of Cell Y.

Which of the above conclusions made by James are incorrect?

- (1) A and D only
- (2) B and C only
- (3) A, B and D only
- (4) A, B, C and D

20. Study the circuit below.  represents a buzzer connected to the circuit. There are 4 switches in the circuit.

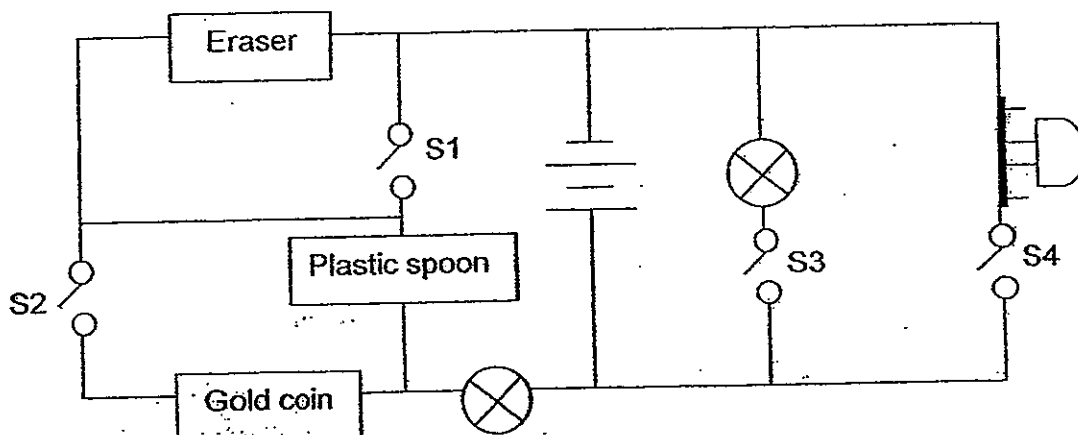

Which of the following will result in the sounding of the buzzer, but with only one bulb lighted up?

	S1	S2	S3	S4
(1)	closed	open	open	closed
(2)	open	closed	open	closed
(3)	closed	closed	open	closed
(4)	closed	closed	closed	closed

21. Study the circuit diagram below.

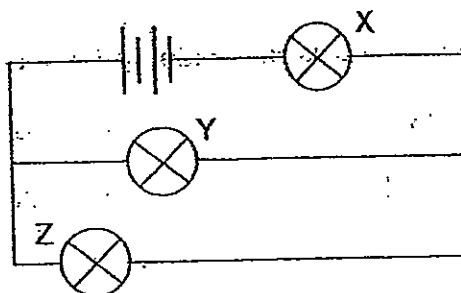

Which of the bulb(s) will remain lit when bulb Y fuses?

- (1) X only
- (2) Z only
- (3) X and Z
- (4) None of the bulbs.

22. Which one of the following circuit arrangements is most likely used for traffic lights?

Key	
R:	Red light
A:	Amber light
G:	Green light
S:	Switch

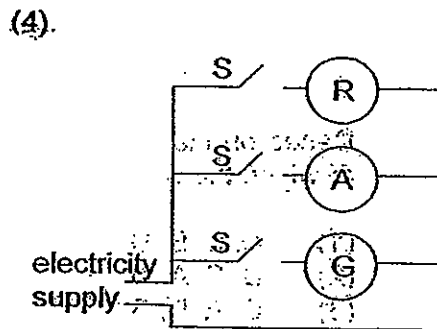
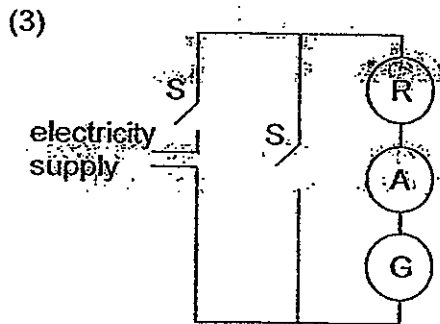
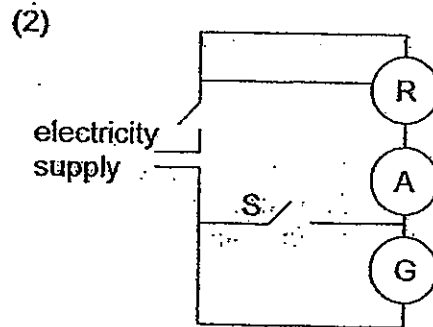
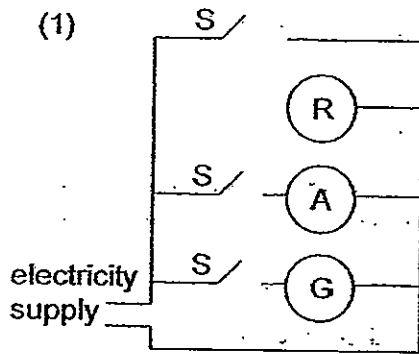

23. The diagram below shows a circuit and what happens to the bulb when four rods, A, B, C and D, are placed, one at a time, across PQ.

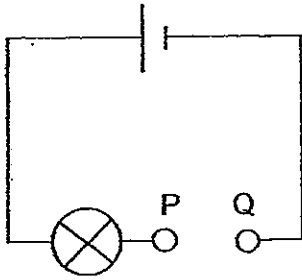

Rod across PQ	Bulb lights up
A	No
B	Yes
C	Yes
D	No

In another experiment, some wax was placed on the top end of the same four rods, A, B, C and D. The four rods were then placed on top of a hot surface as shown below.

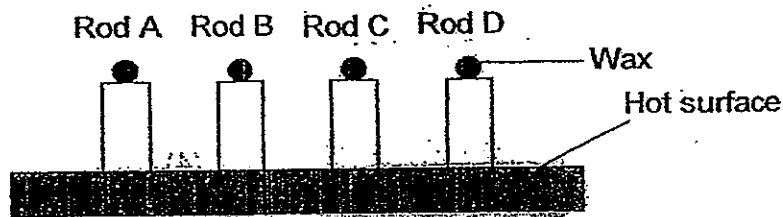

Based on the results of the first experiment, arrange the rods in the order of which the wax would melt from the fastest to the slowest.

- (1) A, C, B, D
 (2) B, C, A, D
 (3) C, A, D, B
 (4) D, A, B, C
24. Mrs Lee attended a seminar and learnt some ways to minimize the wastage of electricity. Which of the following ways are not effective in saving electricity?
- A Use air-conditioners instead of fans on a hot day.
 B Clear the dirt from air filters of air-conditioners regularly.
 C Use energy-efficient electrical appliances and energy-saving lamps.
 D Use paint of dark colour for interior walls, so that a low intensity lamp can be used.
- (1) A and D only
 (2) B and C only
 (3) A, B and C only
 (4) A, C and D only

27. Study the classification diagram below.

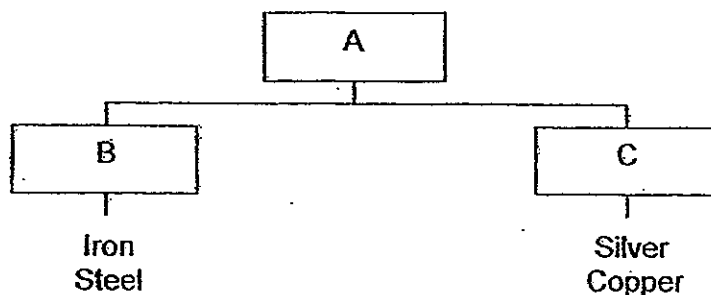

Which one of the following descriptions about A, B and C is correct?

	A	B	C
(1)	Magnets	Can be attracted by a magnet	Cannot be attracted by a magnet
(2)	Metals	Can be made into magnets	Cannot be made into magnets
(3)	Metals	Poor conductors of heat	Good conductors of heat
(4)	Materials	Insulators of electricity	Conductors of electricity

28. The table shows the development of the life cycle of an insect.

Development of the life cycle	Date
The egg was laid in water	1 June
The egg hatched into a larva	5 June
The larva turned into a pupa	19 June
The pupa became an adult	26 June

Based on the data above, which of the following statements are true?

- A The adult insect is able to fly.
 - B There are 4 stages in its life cycle.
 - C The animal is likely to be a dragonfly.
 - D It took more than 3 weeks to complete the life cycle.
- (1) A and C only (2) B and D only
 (3) A, B and D only (4) B, C and D only



NAN HUA PRIMARY SCHOOL
SEMESTRAL ASSESSMENT 2 – 2012
PRIMARY 5

SCIENCE

BOOKLET B

14 Open-ended questions (40 marks)

Total Time for Booklets A and B : 1 hour 45 minutes

INSTRUCTIONS TO CANDIDATES

1. Write your name and index number in the space provided.
2. Do not turn over the page until you are told to do so.
3. Follow all instructions carefully.
4. Answer all questions.
5. Write your answers in this booklet.

Marks Obtained

Section B

	/40
--	-----

Name: _____ () Class: P 5 _____

Date : 23 October 2012

Parent's Signature: _____

Section B: (40marks)

Write your answers to question 31 to 44 in the spaces provided.

The number of marks available is shown in brackets [] at the end of each question or part question.

31. Flask A contained some salt solution at the beginning of the experiment. Then the salt solution was heated and boiled continuously over a period of time. As a result, water vapour was accumulated inside Flask A

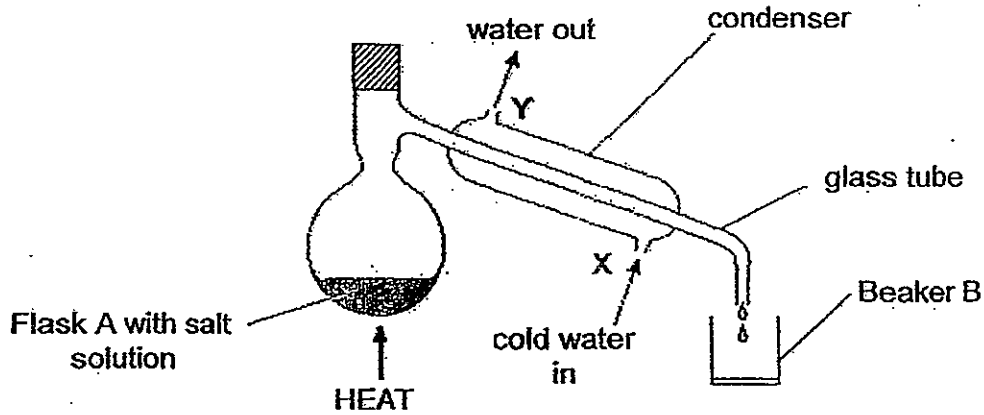

- (a) What happened to the water vapour as it passed down the glass tube in the condenser? [1]

- (b) Water at 5°C entered the condenser at X. Will the temperature of the water which left the condenser at Y be higher or lower than 5°C? Explain the change of temperature. [1]

- (c) Would the water collected in Beaker B be salty? Give a reason for your answer. [1]

Score	3
-------	---

32. Study the diagram below.

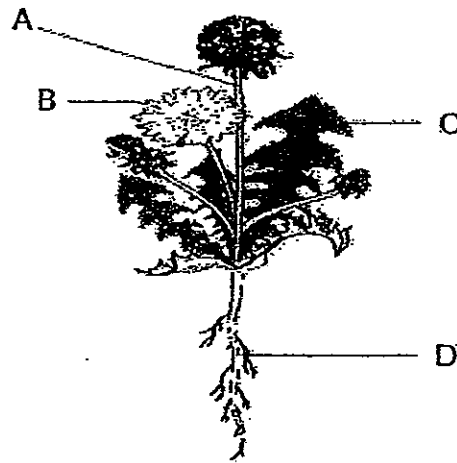

(a) Each labelled part of the plant above has a different function. In the table below, write the letters of the correct part next to its function. [1]

Function of part	Label of the correct part
For absorbing mineral salts.	
For reproduction.	

(b) The diagram below shows a dandelion plant growing in a field.

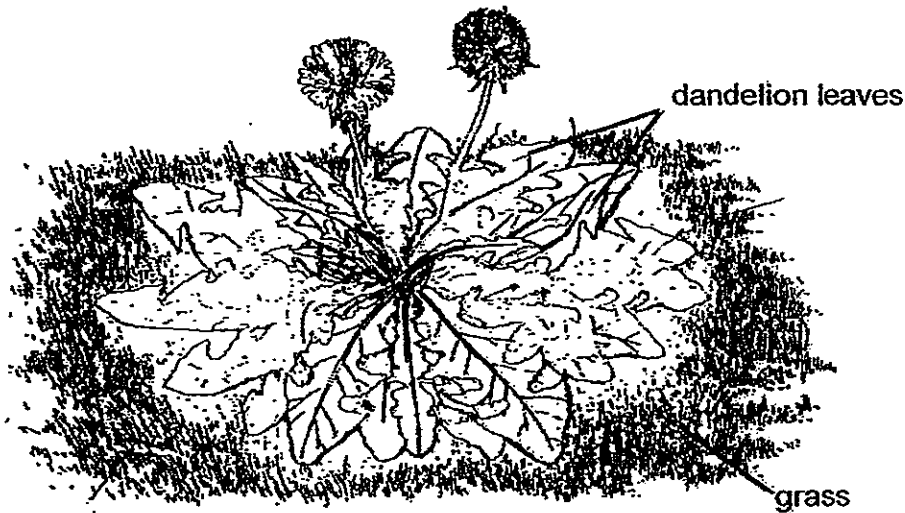

Explain why there is hardly any grass growing under the dandelion leaves. [1]

Score	2
-------	---

33. Sandy measured the volume of air she breathed in and out of her lungs. The graphs below represent the volume of air Sandy breathed in and out with each breath before and during exercise.

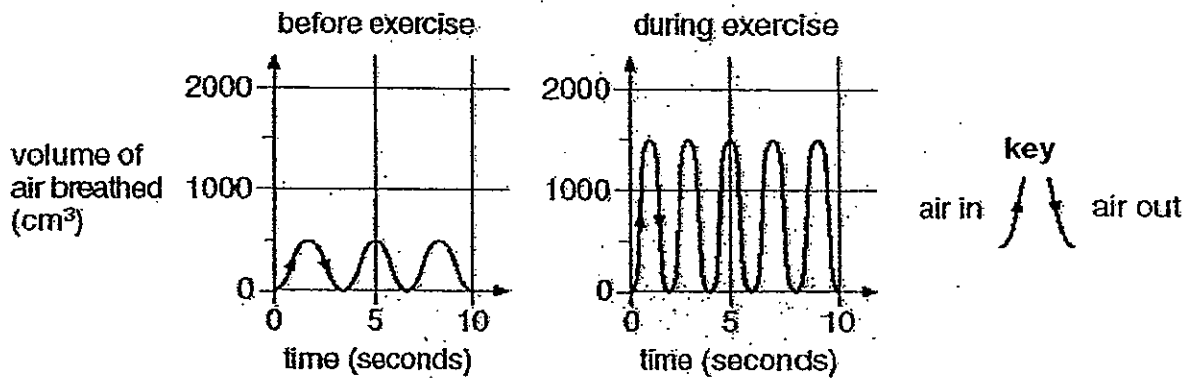

- (a) During exercise, Sandy breathed more air in and out of her lungs than before exercising. How much more air did Sandy breathe in with each breath during exercise? [1]

- (b) Explain clearly why Sandy needed to breathe in more air during exercise. [2]

Score	3
-------	---

34. The diagram below shows a cell and some of its parts.

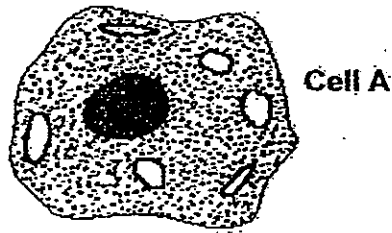

(a) Name the cell part that controls the activities of Cell A. [1]

(b) Tom said that Cell A is a plant cell. His brother told him that he was wrong. Do you agree with his brother? Explain your answer. [1]

35. Study the circuits below carefully.

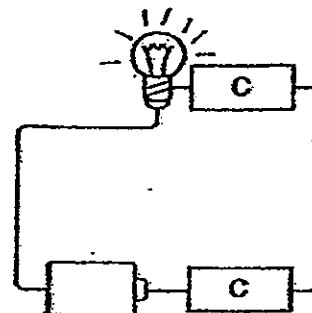
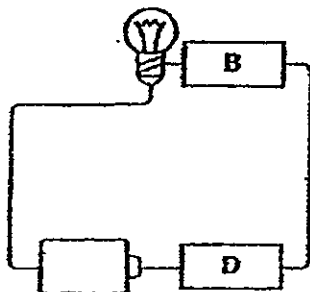
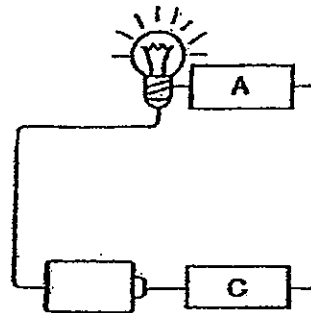
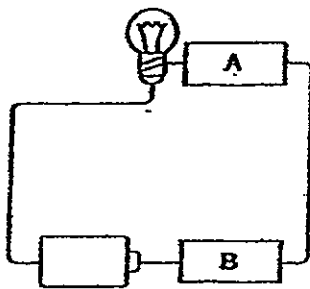

Put a tick (✓) in the table below to indicate if the materials (A, B, C and D) are conductors or insulators of electricity or not possible to tell. [2]

Material	Conductor	Insulator	Not possible to tell
A			
B			
C			
D			

Score	4
-------	---

36. Jane poured 250 ml of icy cold water into a cup and placed it on a weighing machine as shown below. The mass of the cup of icy cold water was 270g at the beginning of the experiment.

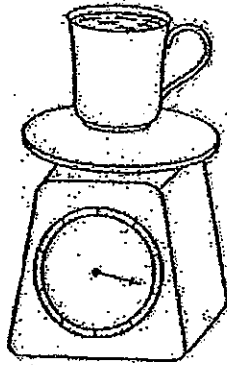

She recorded the mass at every 10-minute interval and plotted the results in the graph below.

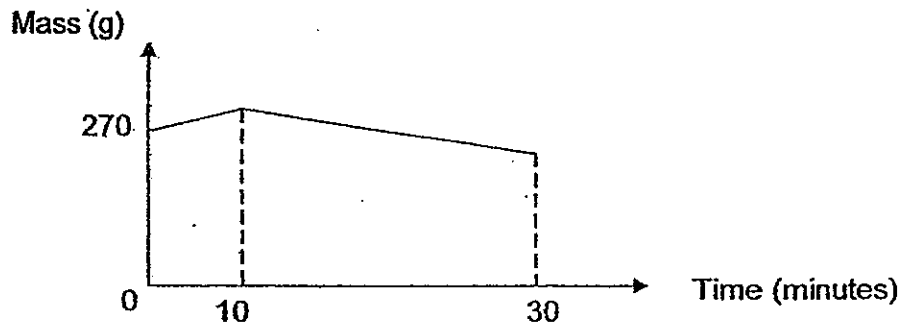

- (a) What caused the mass of the cup of ice-cold water to increase during the first 10 minutes? Explain your answer clearly. [2]

- (b) What caused the mass to decrease after 10 minutes? [1]

Score	3
-------	---

37a. The diagrams in Column A of the table below show various forms of reproduction: In Column B, circle the form of reproduction (asexual or sexual) shown by each of the diagrams. [1]

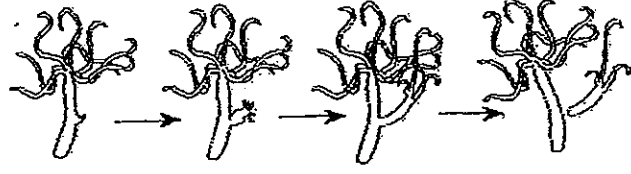
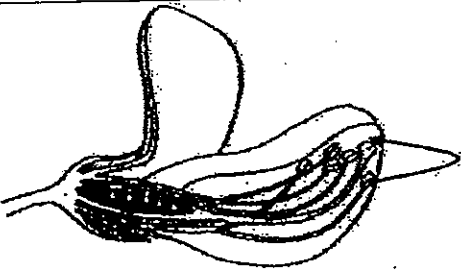
Column A	Column B
	<p>Asexual</p> <p>Sexual</p>
	<p>Asexual</p> <p>Sexual</p>

37b. The diagram below shows the sexual reproduction of an organism.

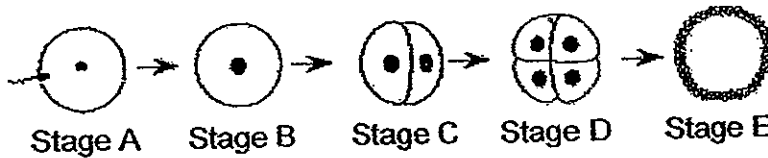

(i) Identify the sex cells shown at Stage A. [1]

(ii) What is the process that is occurring at Stage A and between Stages C and D? [1]

Stage A: _____

Stages C & D: _____

Score	3
-------	---

38. The drawing below shows part of an Arizona poppy plant.



(a) Photosynthesis takes place in the leaves of the Arizona poppy plant. Complete the word equation for photosynthesis.

[1]

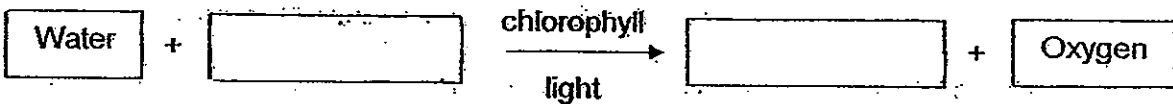

(b) Qian Qian studied an Arizona poppy plant growing in a shady place and an Arizona poppy plant in a sunny place. She found that the poppy plant in the shady place has leaves with a different surface area as compared to the poppy plant found in a sunny place.
Do you think the leaves in the shady place have a bigger or smaller surface area? Explain your answer.

[2]

Score	3
-------	---

39. Iskander set up an experiment to investigate the effect of different light intensity on the rate of photosynthesis. He carried out his investigation as follows.

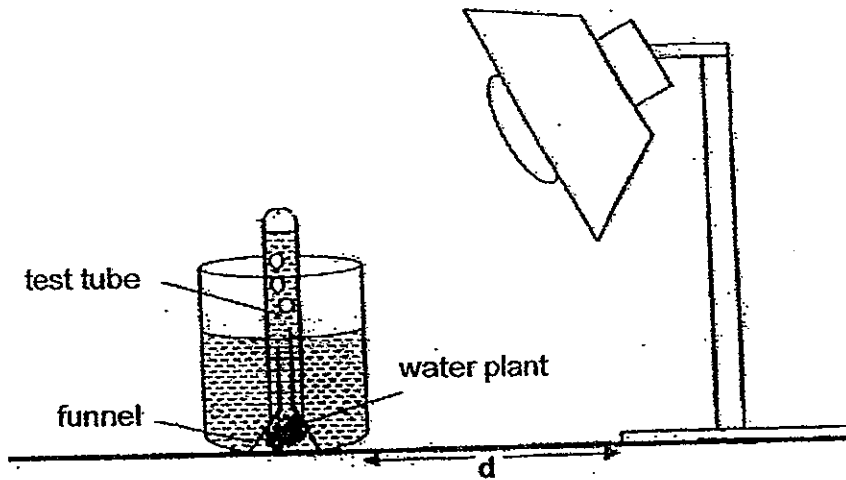

He changed "d", the distance between the lighted bulb and beaker, and recorded the number of bubbles produced per minute at each position in the table below.

Distance between the lighted bulb and beaker (cm)	40	35	30	25	20	15	10	5
Number of bubbles per minute	6	8	10	12	14	16	16	16

- (a) What conclusion can you draw from the results of Iskander's experiment? [1]

- (b) On the axes, draw a line graph to show the relationship between the number of bubbles per minute and light intensity. Label the axes. [2]

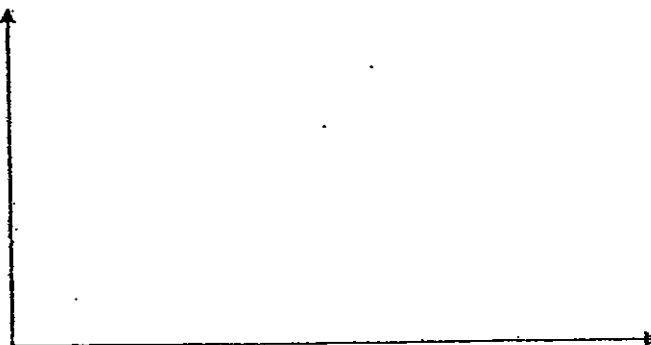

40. Ian carried out an experiment as shown in the diagram below. He turned on the Bunsen burner and turned it off after 5 minutes.

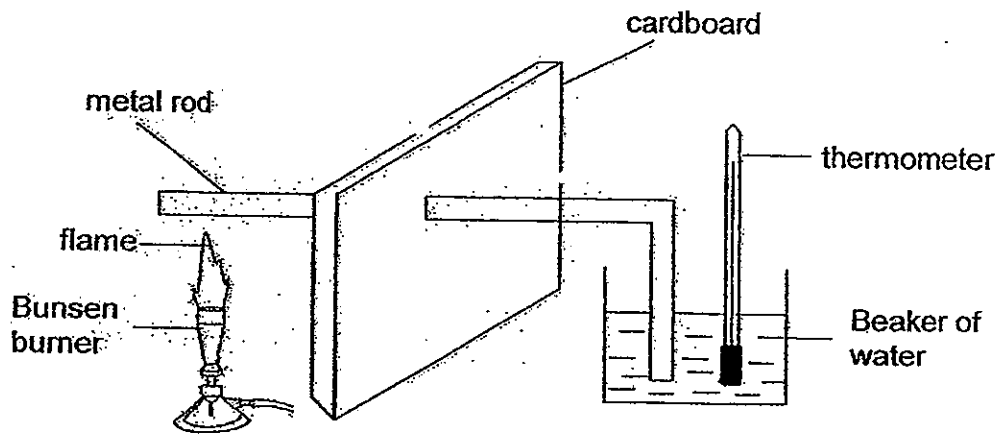

- (a) What is the aim of Ian's experiment?

[1]

- (b) What data does Ian have to collect and record in his experiment before he can make his conclusion?

[1]

Score	2
-------	---

41. Sam built a circuit with 3 identical bulbs and two batteries. He covered the connections to the bulbs with a piece of card as shown below. The bulbs could be seen through holes in the card.

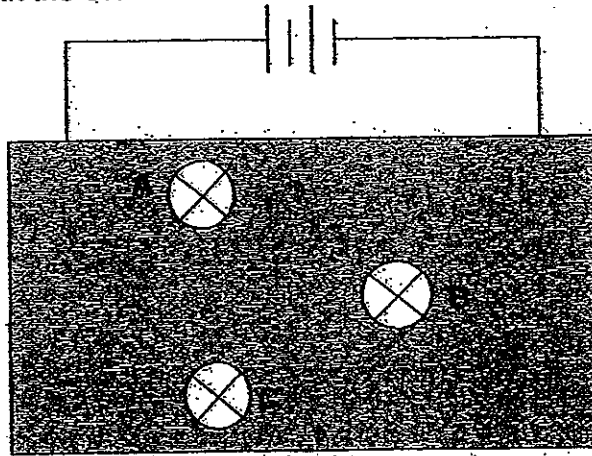

All the bulbs were lit but their brightness was different. Sam removed bulbs A, B and C one at a time. Before connecting each bulb back into the circuit, he observed and recorded the effect on the other two bulbs.

Bulb removed	Observations
A	B and C remained lit
B	C became unlit and A remained lit
C	B became unlit and A remained lit

- (a) Draw a circuit diagram to show how the 3 bulbs could be connected.

[2]

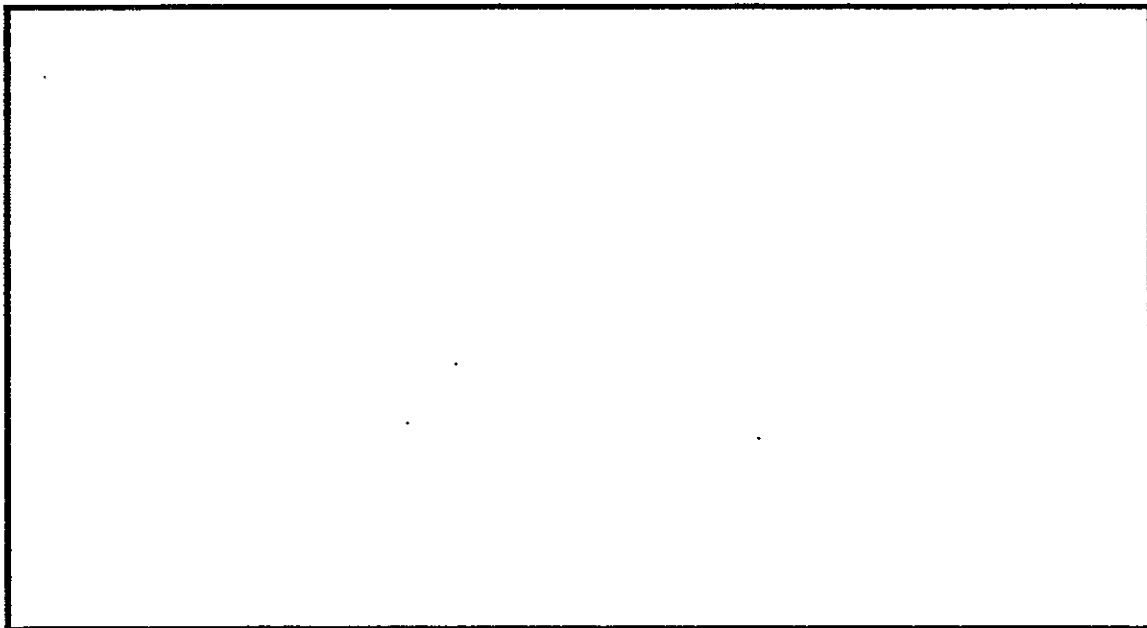

Score	2
-------	---

- (b) Sam wanted to put 3 bulbs in 3 different rooms. Construct another circuit to help Sam install the bulbs in the 3 different rooms such that he could control the bulbs independently. [2]

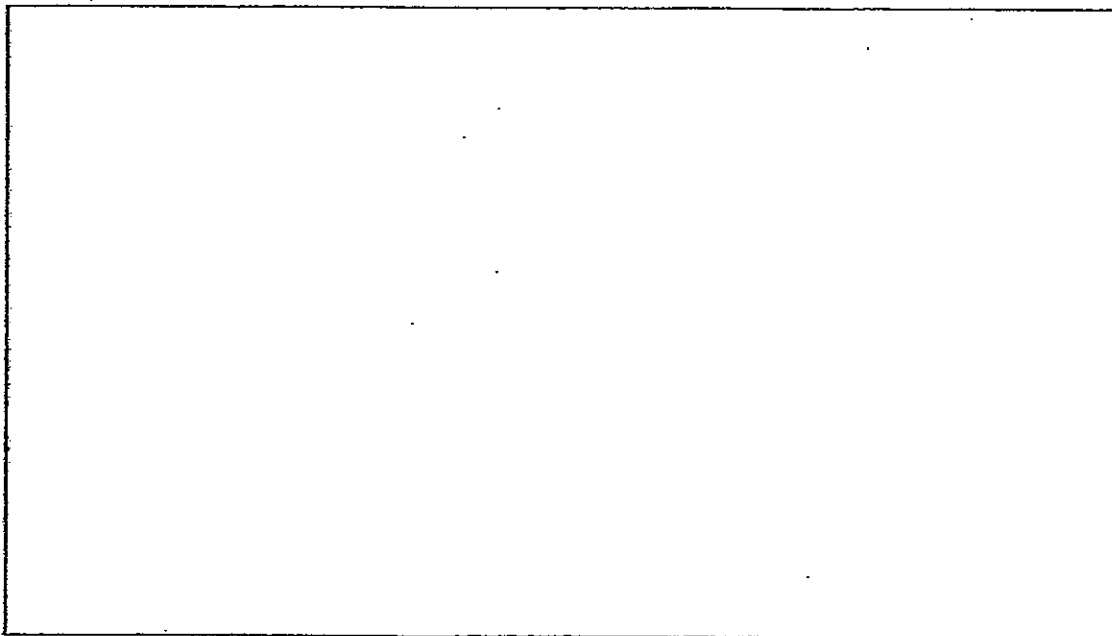

Score	2
-------	---

42. Mandy used the apparatus below to investigate the strength of an electromagnet.

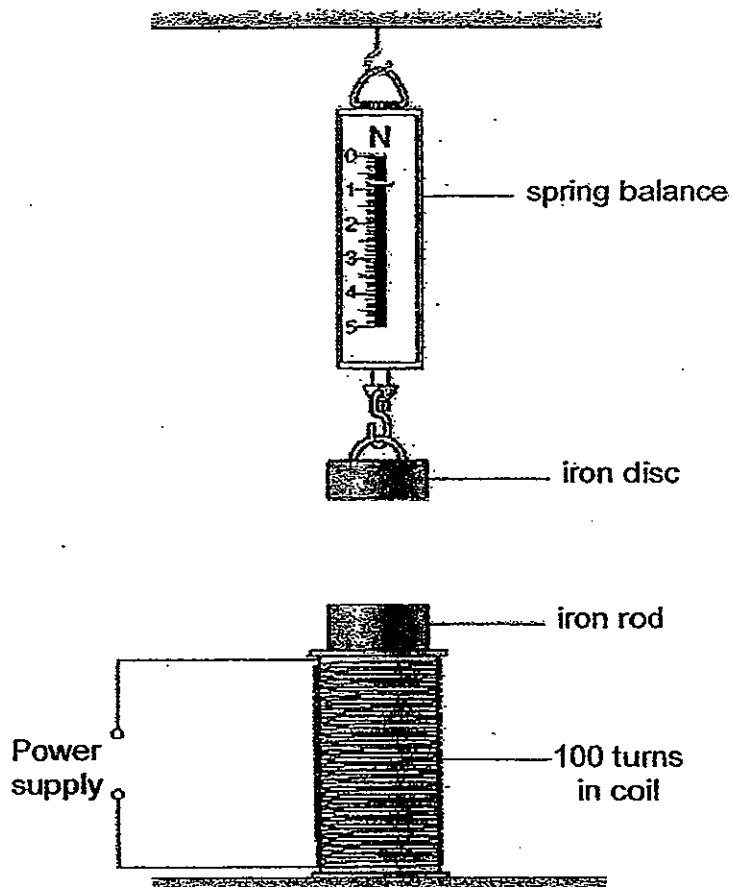

(a) Explain clearly what will happen to the iron disc when a current passes through the coil. [2]

Score	2
-------	---

(b) Mandy made two electromagnets, one with 100 turns of wire in the coil and one with 200 turns. She varied the current through the coil of each electromagnet. She measured the force of each electromagnet on the iron disc using the spring balance. The graph on the next page shows her results.

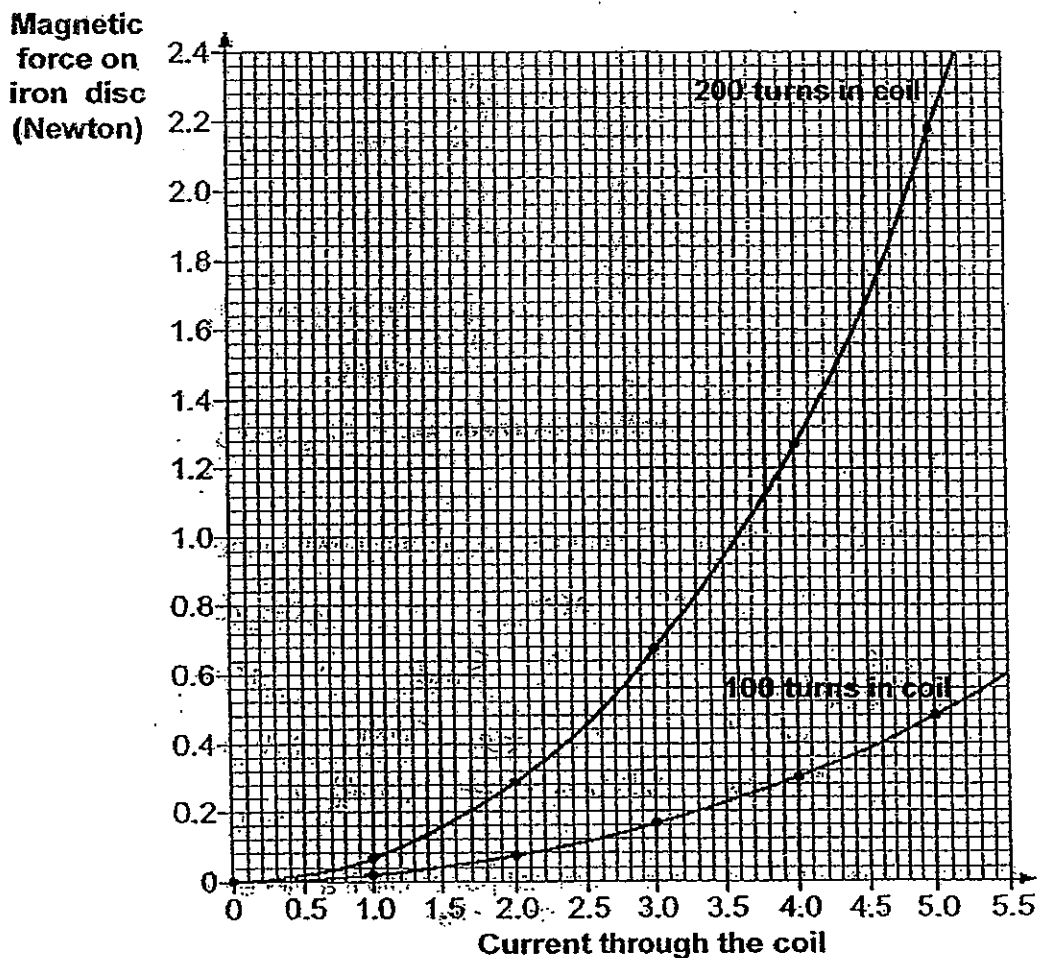

(c) Based on the results, write down two conclusions that Mandy could make? [2]

Score	2
-------	---

43. The diagram shows a metal paper clip attached to the base of a ring stand with a string. A magnet is attached to the ring stand with a clamp.

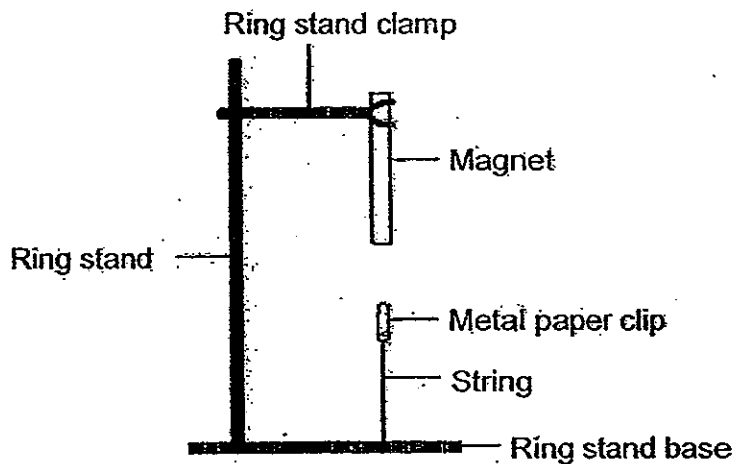

- (a) Explain why the metal clip is floating in the air as shown in the diagram? [1]

- (b) Explain what would happen to the metal paper clip if a piece of iron sheet is placed between the magnet and the metal paper clip. [2]

44. The diagram below shows an experiment conducted to see how quickly water moves through different-sized particles of the same substance.

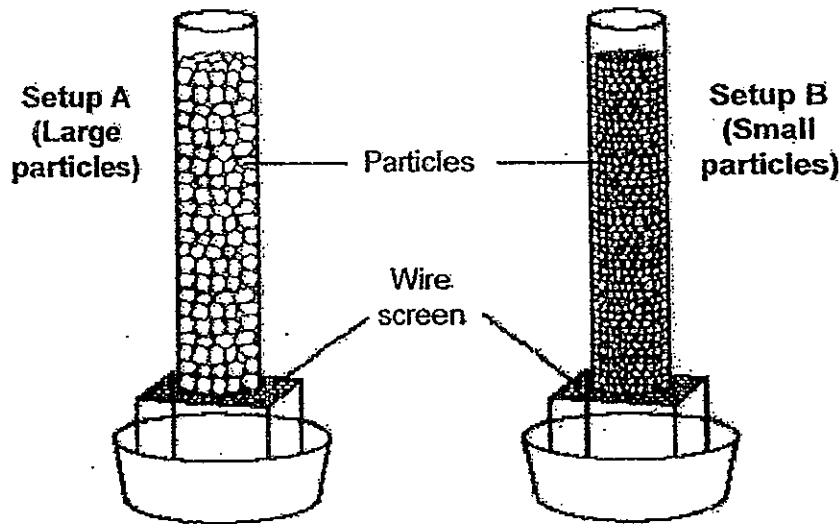

Two identical columns contained equal volumes of different-sized particles. The same amount of water was added to the top of each column.

- (a) Which setup, A or B, will allow water to pass through more quickly? Explain your answer. [2]

- (b) Another similar experiment was conducted to find out how quickly water passes through 3 types of soil. The different types of soil also have different-sized soil particles. The data table below shows the results.

Sandy	16
Clayey	55
Garden	34

Based on the results, what can conclude about clayey soil? [1]

Score	3
-------	---

Answer Ke

EXAM PAPER 2012

SCHOOL : NAN HUA
SUBJECT : PRIMARY 5 SCIENCE

TERM : SA2

Q1	Q2	Q3	Q4	Q5	Q6	Q7	Q8	Q9	Q10	Q11	Q12	Q13	Q14	Q15	Q16	Q17
4	1	4	1	4	2	2	3	2	2	3	2	1	1	4	2	1

Q18	Q19	Q20	Q21	Q22	Q23	Q24	Q25	Q26	Q27	Q28	Q29	Q30
4	3	3	3	4	2	1	3	3	2	2	2	3

31)a)The water vapour lose heat to the cold water and condense into water droplets.

b)The temperature will be higher. The water had gain heat from the hot water vapour and increased in temperature.

c)No. Only pure water can evaporate and the water from the salt solution will evaporate, leaving the salt behind.

32)a)D B

b)Grass requires sunlight to make food but the big leaves of the dandelion will prevent sunlight from passing through, hence there is hardly any grass growing under the leaves.

33)a)1000cm³

b)When Sandy exercise, she needed more oxygen to break down digested food into energy as her muscles needed more energy, when she breathe in, she would obtain oxygen from the air and will give out more carbon dioxide, therefore she needed to breathe in more air during exercise to take in more oxygen.

34)a)Nucleus.

b)Yes. All plant cells have a cell wall but cell A does not have a cell wall hence it is not a plant cell.

35)A: Conductor B: Insulator C: Conductor D: Not

36)a)The hot water vapour from the surroundings lose heat to the cooler outer surface of the cup, condensing into water droplets and the water droplets has mass, therefore increasing the mass.

b)The icy cold water gain heat from the surroundings and was not cool anymore and the water droplets will not be there to increase the mass and some of the water in the cup evaporating, causing the decrease.

37)a)Asexual Sexual

b)i)Sperm and Egg. ii)A: Fertilisation C&D: Cell Division

38)a)Carbon Dioxide Glucose

b)Larger shady place has low light intensity. The leaves have to be bigger to capture more sunlight for photosynthesis.

39)a)He can conclude that the greater the light intensity, the greater the rate of photosynthesis until 15cm after that, the rate of photosynthesis remains the same.

b)

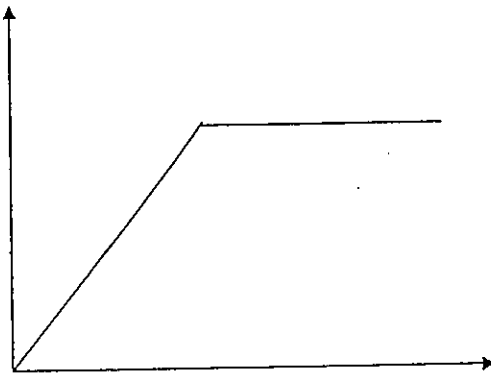

40)a)To find out if the metal rod conduct heat.

b)He have to record the temperature of water at the start of the experiment and check the temperature of water every 5 minutes and record it.

41)a)

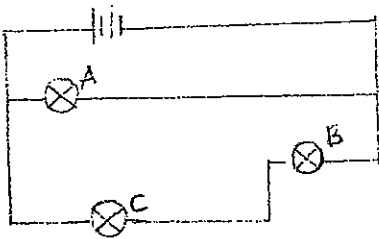

b)

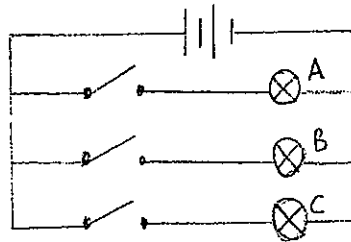

42)a)When a current passes through the coil, the iron rod will become an electromagnet and attract the iron disc which is made of a magnetic material.

c)The greater the number of turns in the coil the stronger the electromagnet. The greater the current, the stronger the electromagnet.

43)a)Since magnetism can act from a distance, the metal paper clip is attracted to the magnet.

b)Magnetism cannot pass through the iron sheet which is a magnetic material, hence the metal paper clip will not be attracted to the magnet and will drop to the ring base.

44)a)Setup A. Setup A has larger particles than B. Larger particles have more air spaces between them, hence water can flow through more quickly.

b)Clayey soil has the smallest soil particles and allows the water to pass through the slowest.

